

LE300

Technical Spec Sheet



About the LE-300

The LE-300 Extreme is small direct drive micro-turbine designed for use in many difficult and demanding applications. Its aesthetic low profile design, coupled with its unparalleled low wind regime performance and low rotor acoustics make this turbine the ideal choice – whatever your application – from electric fencing to CO2 abatement or off-grid homes.

The LE-300 Extreme features a fully integrated 3-phase Permanent Magnet Generator (PMG) that takes advantage of the latest, most powerful neodymium iron boron magnet technology. This configuration gives the PMG excellent low RPM characteristics with a very low cut-in speed allowing the turbine to spend more time generating power.

The uniquely designed and manufactured turbine blades work in harmony with the PMG to allow the turbine to operate at low wind speeds, low RPM and with low acoustic emissions. Of equal importance, is the LE300's ability to run at high output during 'big' winds for prolonged periods - it is protected by a high-speed thermal cut-out which prevents the turbine over-heating in constant, very high winds.

This means that a LE-300 Extreme will generate more kWhs in an average wind regime -compared to competitor products that are 'rated' at an unrealistic 12m/s (27mph). In optimum conditions, with an average wind speed of just 5 m/s (11mph), a single LE-300 Extreme could generate as much as 40kWh per month of free and clean renewable energy. That represents a CO2 abatement of 18kgs per month.

The innovative and versatile micro-turbine designed for superior performance at low wind speeds.

LE-300 Extreme features

- Low TSR rotor blades with excellent low wind speed performance, and exceptionally low acoustic emissions.
- Rotor blades are injection moulded for excellent consistency.
- Rated at just 8m/s for superb low wind speed performance.
- Proprietary low inertia axial flux generator using Neodymium Iron Boron magnets.
- Our unique ironless generator design has no 'cogging', which allows effortless start up in low winds and reduces 'generator hum'.
- The 3-phase output from the generator is rectified onboard for a DC output.
- CNC machined components throughout.
- Constructed from powder coated / anodized aluminium and stainless steel.
- Aesthetically pleasing and low visibility profile.
- Oversized tail fin for excellent response to turbulent wind condition
- Designed to run through severe weather conditions
- Unique bearing configuration resulting in low friction, low bearing noise.
- All bearings a lubricated and sealed for life
- Anti-vibration fixings used throughout.
- All-up weight of just 5.5kg

Estimated Annual Energy Production

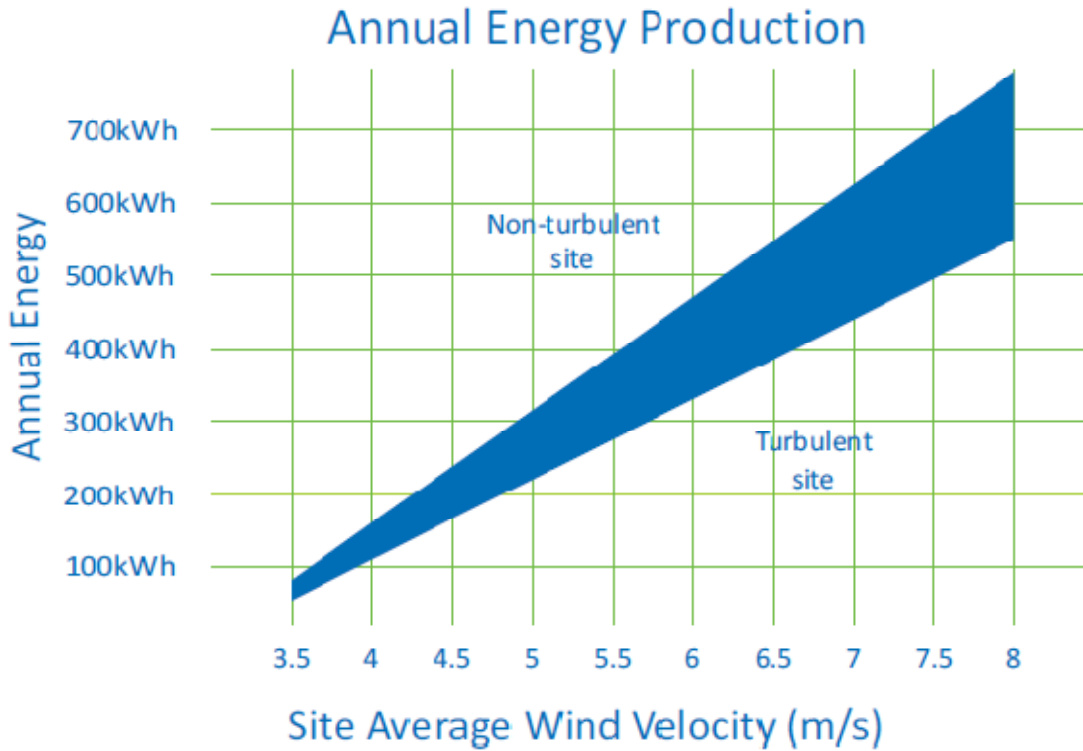

Estimated Power Curve

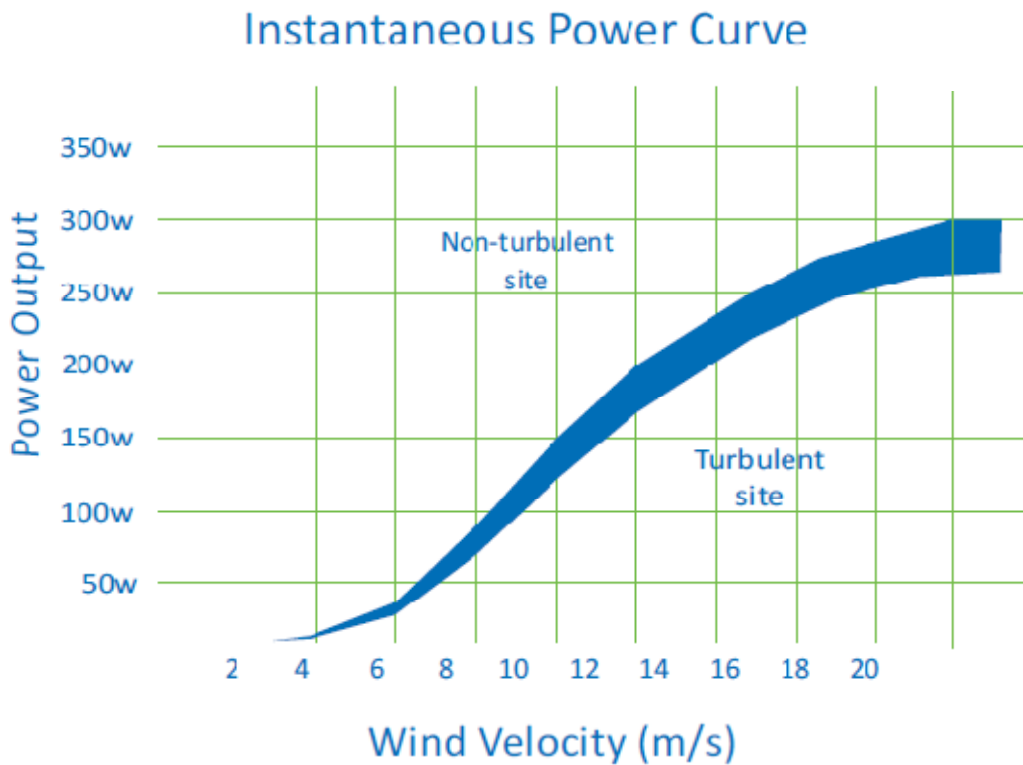

LE300

Technical Spec Sheet

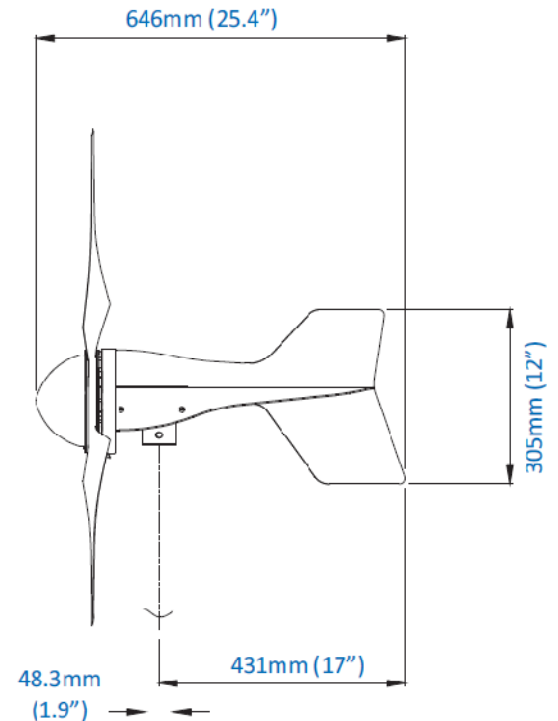
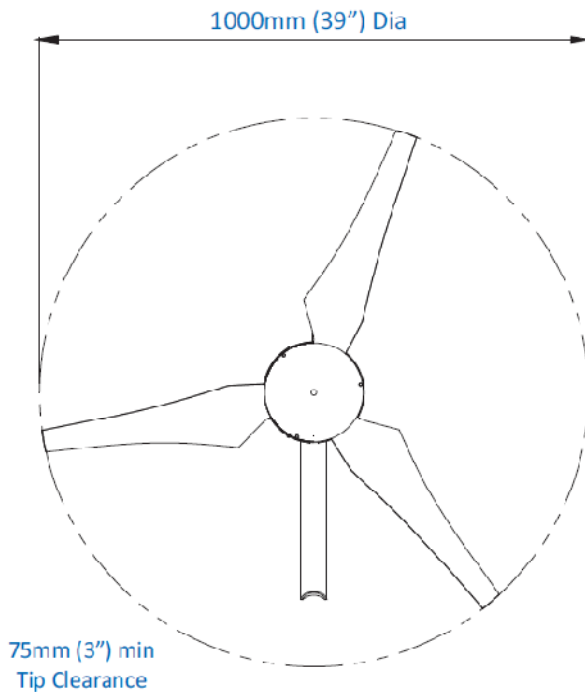

Specifications

Rotor Diameter:	1 metre
Rotor Type:	3-Blade upwind
Blade Material:	Glass Reinforced Composite
Rated Output:	85watts @ 8m/s (18mph)
Peak Output:	300watts
Cut-in speed:	3m/s (6.7mph)
Estimated AEP:	250-400kWh per year <i>Depending on site location & wind</i>

Weight:	5.5Kg
Generator Type:	3-Phase Brushless NIB rotor PMA
Output voltage:	12 or 24V
Lifetime & Servicing:	20 years Annual inspection recommended
Warranty	2 years